

# ERA

## DLPED Decorative Letterplate Fitting Instructions

### Installing a Decorative Letterplate

To fit a letterplate you will require the following tools:

- Pencil
- Tape Measure
- Drill
- Screwdriver
- Hacksaw

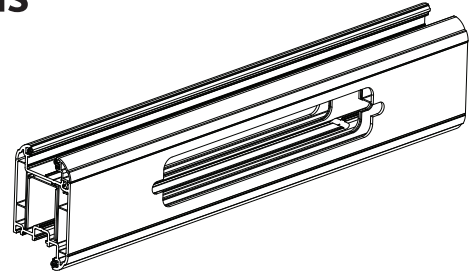

### Caution

This letterplate is suitable for doors 40mm - 80mm thick and used on the midrail of a door only, please check this letterplate is suitable for the door, prior to fitting. If replacing an existing letterplate, please also check the routing dimensions to ensure a good fit, you may need to make the current rout larger. Screws may also need to be shortened to suit the door thickness.

**Important:** prior to installation of the letterplate, ensure that the door has been routed correctly according to the diagram below:

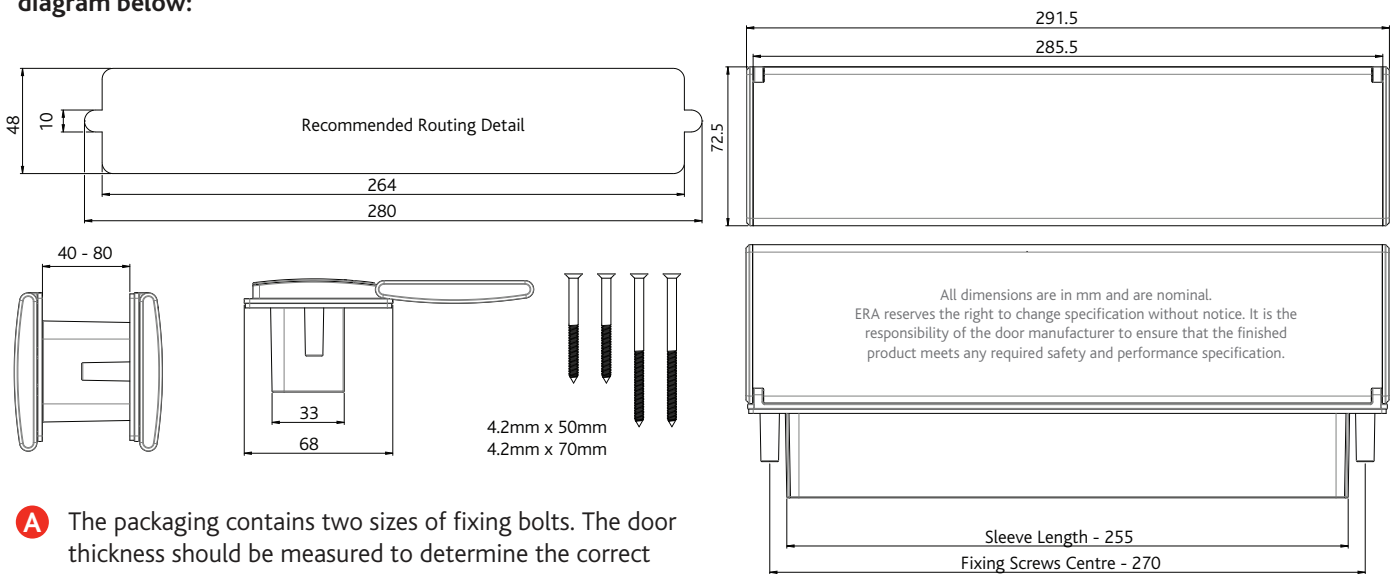

**A** The packaging contains two sizes of fixing bolts. The door thickness should be measured to determine the correct size of bolt.

**B** Identify which is the external and internal side of the letterplate. The external side of the letterplate is identified by attached fixing lugs.

### Additional Information

**Please note:** This letterplate is only suitable for doors 40-80mm thick.

**Maintenance** - Letterplates should be cleaned with a soft dry cloth. If further cleaning is required we recommend a mild solution of warm, soapy water on a soft cloth. Dry thoroughly afterwards.

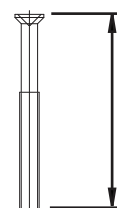

DOOR THICKNESS	BOLT LENGTH	QTY
66.0mm-74.0mm PVCu	70mm	2
42.0mm-48.0mm Timber/Composite	50mm	2

Note : Profile thickness varies and it may be necessary to trim the bolt length to suit.

