

# ERA PROTECT

Smart Universal Door Handle

INSTALLATION GUIDE

FOR  
INSTALLATION

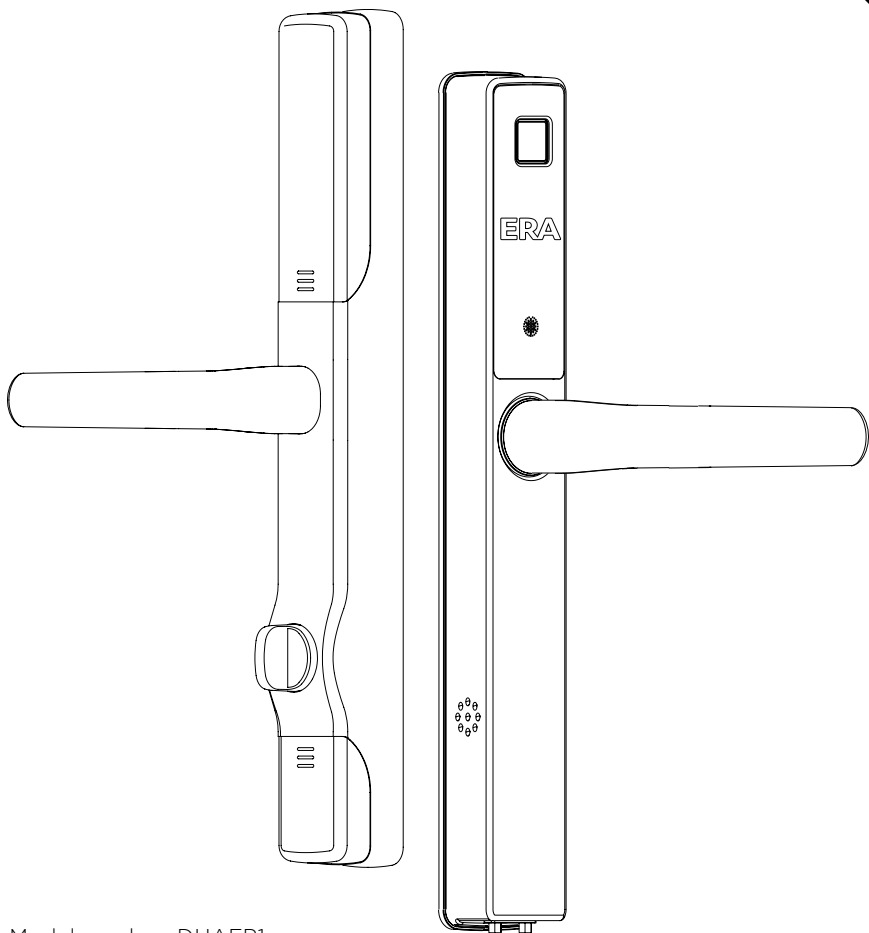

Model number: DHAEP1  
V3



Welcome to **ERA Smart Home** a complete ecosystem for home security.

Visit **eraprotect.com** to find out how to combine your **Smart Universal Door Handle** with ERA's series of smart security devices. Including a smart alarm system, video doorbell, and cameras.

## Here if you need us

Your ERA product is designed to be up and running in minutes, but if you do need help there are lots of handy videos and information available on our website, or contact us for further assistance or support.

Visit **eraprotect.com**  
or call us **0345 646 1487**



**IMPORTANT**

**During installation, please ensure that you hold the door open securely to prevent from closing before handle is fitted and tested.**

# Contents

- 4** Smart Universal Door Handle
- 5** What's in the box
- 6** Remove existing handle and cylinder
- 7** Install the operating cam
- 8** Determine handle direction
- 9** Changing internal hand direction
- 10** Fitting screw pillars
- 11** Measuring door thickness
- 12** Installing the external handle
- 13** Installing the internal mounting plate
- 14** Fitting the drive bar
- 15** Using the fitting jig to align
- 16** Fixing the mounting plate
- 17** Fitting the internal handle
- 20** Setting up the internal handle
- 21** Checking the thumbturn
- 22** Fitting the setting cover
- 23** Creating an account and adding your Smart Universal Door Handle
- 25** Adding your Door Handle to an existing ERA Smart Home account
- 26** Adding an ERA WiFi Connection Hub
- 27** Warranty information
- 28** Important things to remember

# Smart Universal Door Handle

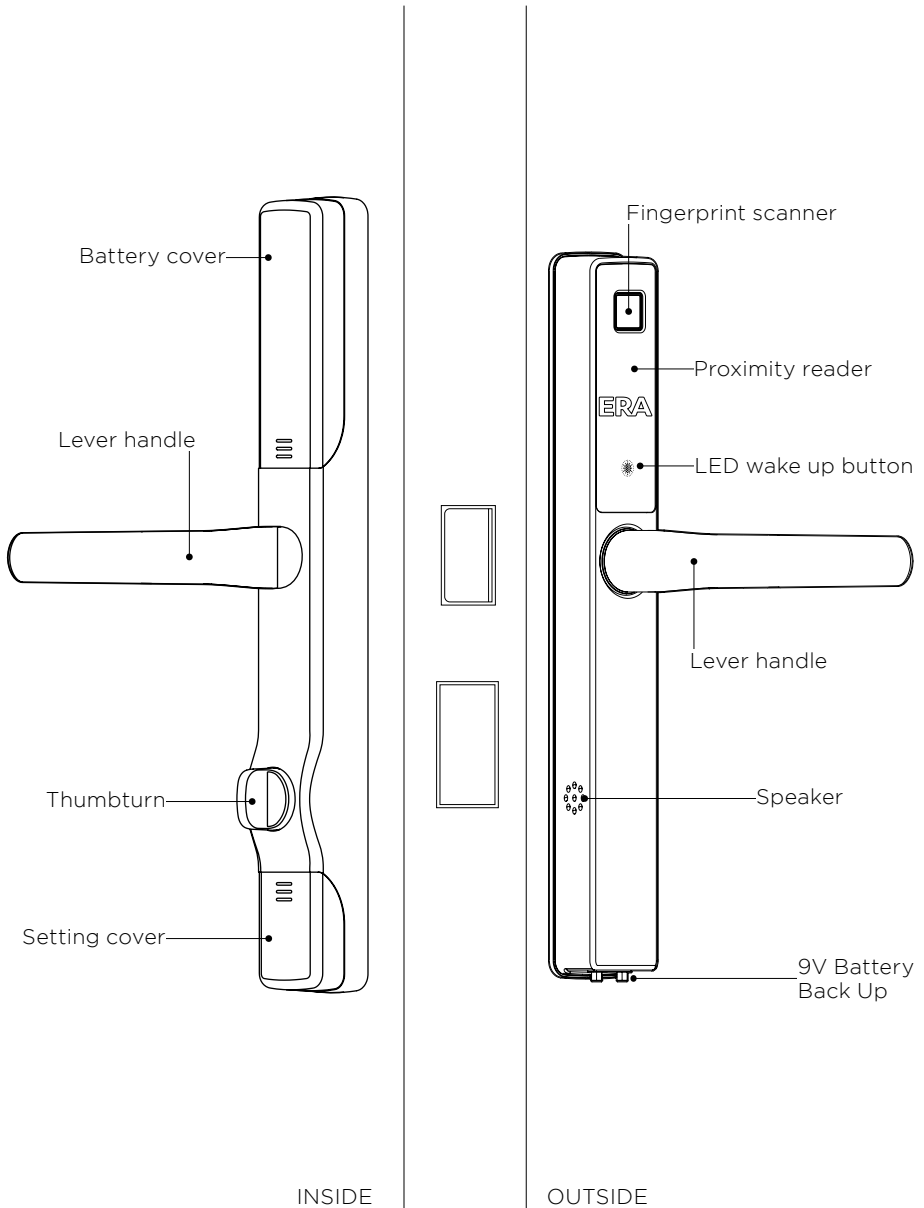

# What's in the box?

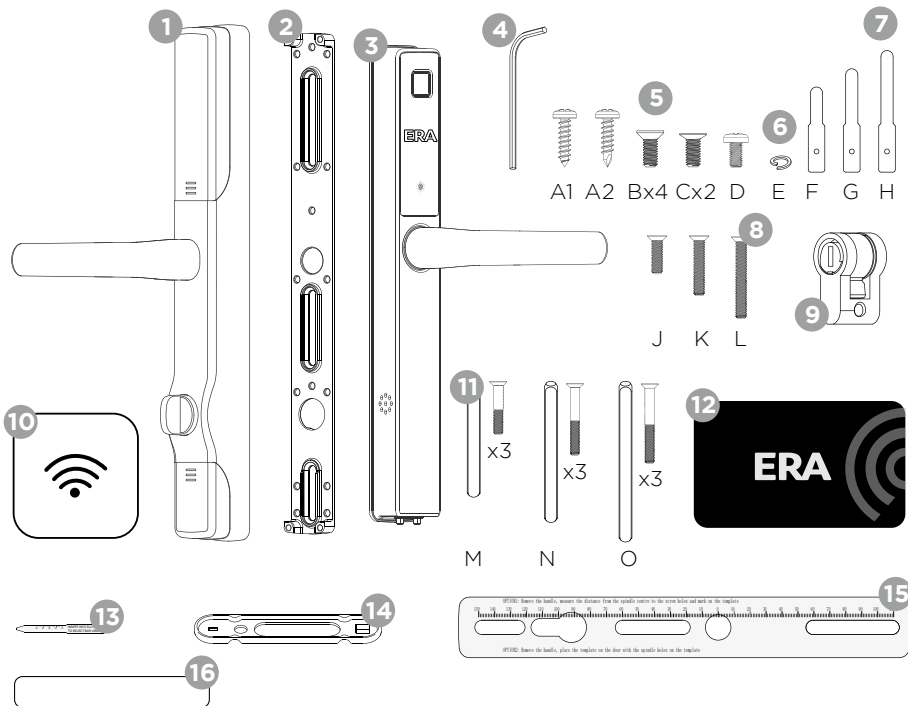

- |                                       |  |
|---------------------------------------|--|
| <b>1</b> INTERNAL HANDLE              | <b>9</b> OPERATING CAM                     |
| <b>2</b> MOUNTING PLATE               | <b>10</b> WIFI CONNECTION HUB (WITH USB-C) |
| <b>3</b> EXTERNAL HANDLE              | <b>11</b> SCREWS AND SPINDLES (M, N, O)    |
| <b>4</b> ALLEN KEY                    | <b>12</b> KEY CARDS (x2)                   |
| <b>5</b> SCREWS (A1, A2, Bx4, Cx2, D) | <b>13</b> SETTING TOOL                     |
| <b>6</b> WASHER (E)                   | <b>14</b> FITTING JIG                      |
| <b>7</b> MEASURING TOOLS (E, F, G)    | <b>15</b> SETTING RULER                    |
| <b>8</b> SCREWS (J, K, L)             | <b>16</b> LEADING TUBE                     |

# Remove existing handle and cylinder

## Important

Please ensure the door is unlocked before removing the handles. Do not close the door until installation is complete. We recommend using something to hold the door open and prevent it from closing during installation.

To remove the existing handle:

- 1 Remove existing screws from the internal handle (2 or 3 screws depending on the handle type). You may wish to hold onto the external handle to prevent it falling. Then remove internal handle.
- 2 Remove external handle and spindles from the door.
- 3 To remove the locking cylinder you will need to firstly remove the fixing screw. Then turn the key/thumbturn whilst putting gentle pressure on the other end of the cylinder until it starts to withdraw. Then gently pull the cylinder from the door. If there is no movement, try turning the key gently left and right to locate the cam in the correct position.

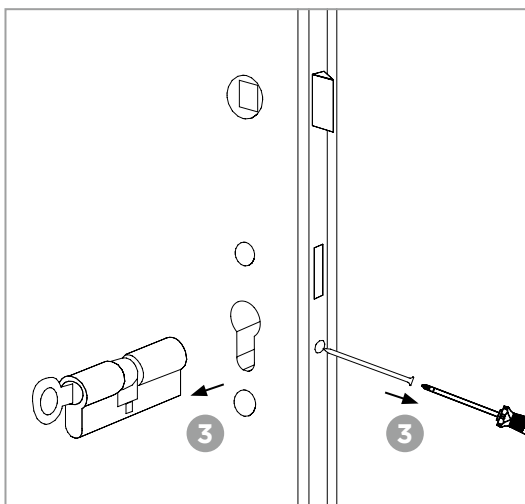
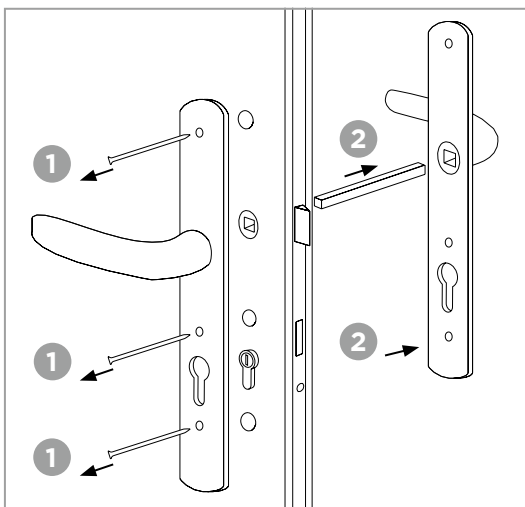

## Information

You may only be able to withdraw the cylinder from the outside or the inside, please try both ways. If a security clamp is fitted, it is recommended to remove the clamp first - an Allen key may be required.

## Important

Please use a manual screwdriver. Do not use a powered screwdriver unless specifically stated within the instructions.

# Install the operating cam

- 1 Insert the setting tool into the operating cam.
- 2 Push the operating cam into the lock (hole where you removed the cylinder from).
- 3 Fix into place with the fixing screw.
- 4 Insert the fixing screw but **do not overtighten**. Remove the setting tool upon completion.

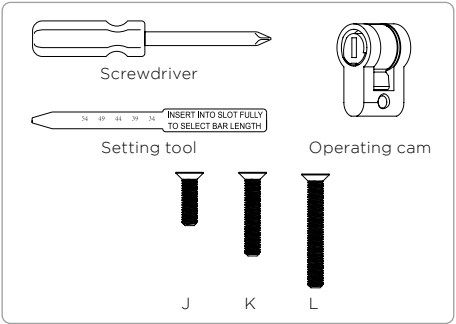

## Information

If the cam is accidentally turned, reset it to vertical by pushing down the pin and turn the cam so the pin is in the central position.

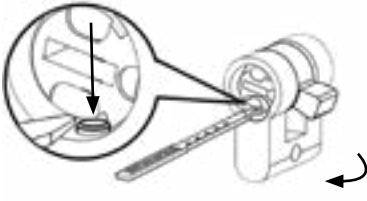

## Important

It is very important not to overtighten the operating cam screw as this may prevent the thumbturn working correctly.

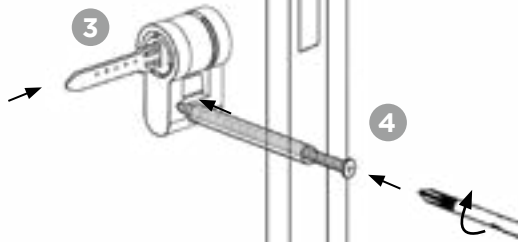
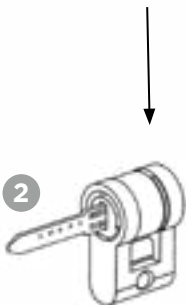
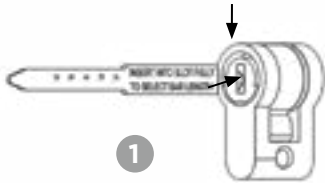

## Determine handle direction

Depending on which way your door opens, you may need to change the direction of the lever to ensure correct operation of your door. You will need to determine which way your handle will need to face in relation to the door hinges.

Please see diagram below, the lever of the door handle should always point towards the door hinges. Check the ERA Smart Handle against the old handles you have removed to confirm.

If the handle orientation needs to be changed, please see instructions for how to do this on the next page. If not, please continue to page 10.

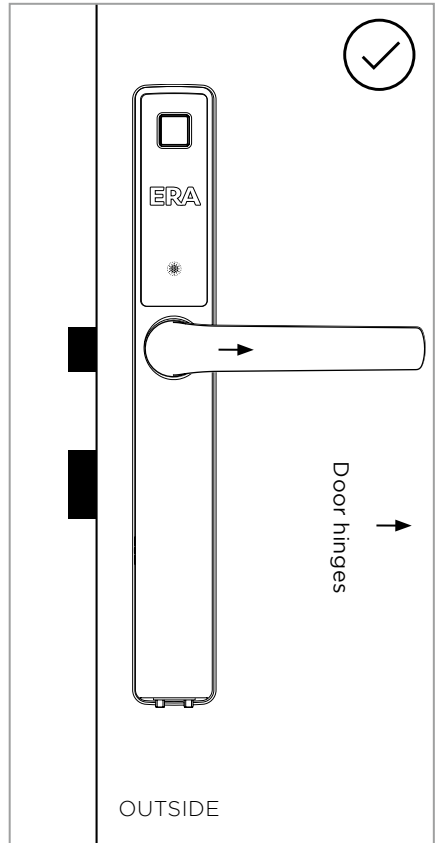
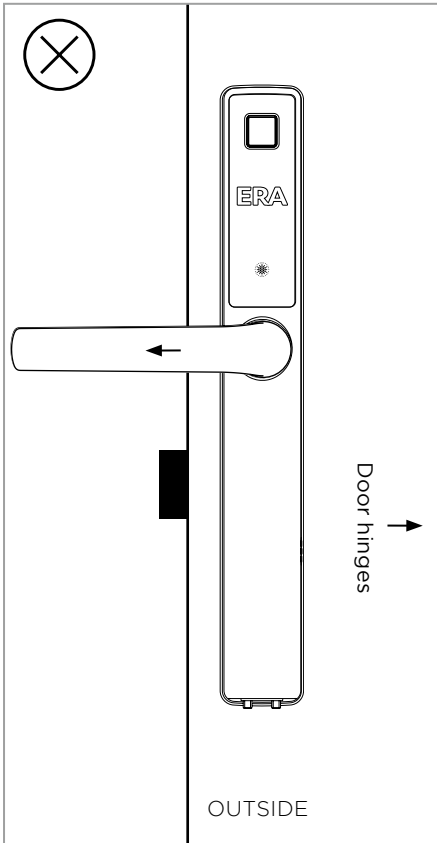



# Changing internal handle direction



Screwdriver



D



Washer

If you need to change the orientation of the lever, please follow the below instructions:

- 1 Insert your screwdriver into the spindle hole on the internal handle as shown left.
- 2 Locate the screw, remove it and discard both the screw and the washer.
- 3 Rotate the lever 180°. Use the new handle screw (D) and the washer (E) from the box to fasten securely.

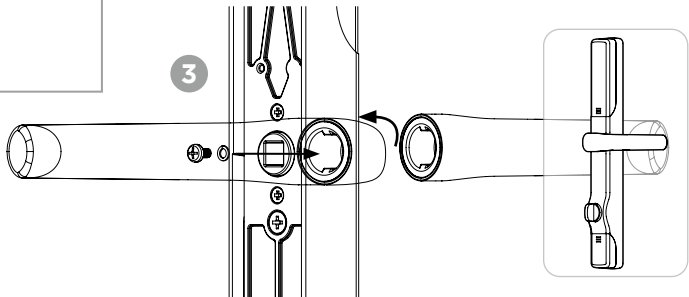
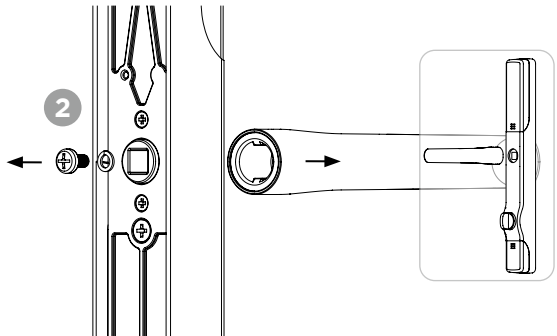
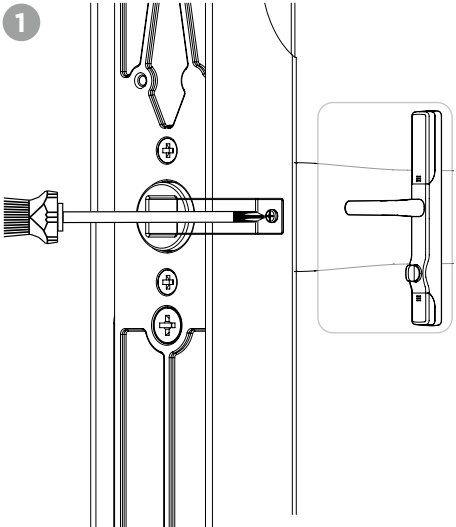

## Information

For external handle, the lever moves freely. Simply rotate the lever to the required position before inserting the spindle.

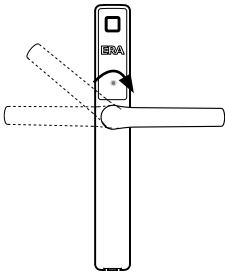



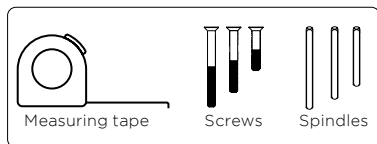

# Measuring door thickness



Please measure the total thickness of your door and select the spindle and fixing screw pack from the diagram.

Door Thickness		
44-50mm	 M	48mm x 3 130mm
58-65mm	 N	60mm x 3 145mm
68-75mm	 O	70mm x 3 155mm

Before proceeding to fit the handle assembly, please ensure that the internal and external handle, backplate, spindle and fixing screws are removed from the packaging and within easy reach.

## Important

Please make sure the main door lock is in the unlocked position. If unsure, use the old handle and spindle and push the handle down before proceeding.

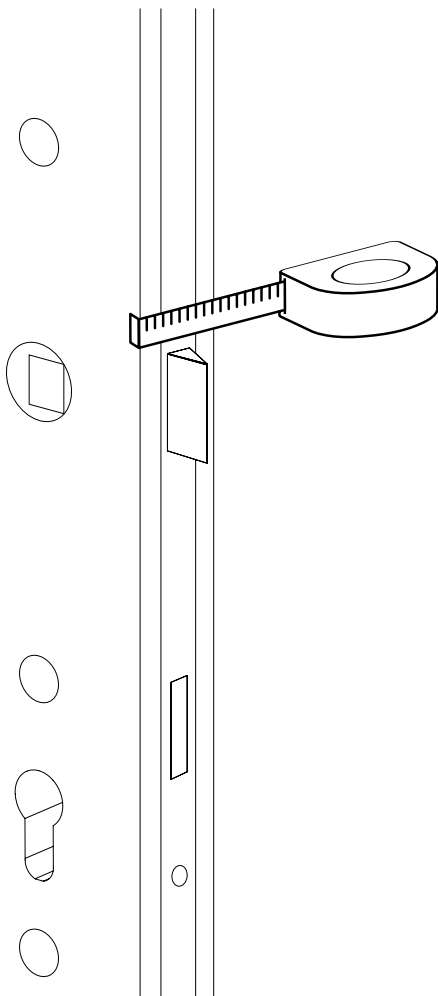

# Installing the external handle

- 1** Please ensure that the lever on the external handle is facing the correct direction (see page 8-9). Fit the spindle into the back of the external handle.
- 2** From the outside face of the door, take the leading tube and push the cable connector head into the tube (this will help feed the cable smoothly through the hole). Then feed the cable through the bottom fixing hole. Please note PVCu doors will have 2 internal walls to pass the cable through as well as the outer and inner walls.
- 3** Line the spindle up and place the external handle onto the door, push all the way through. Make sure the screw pillars pass through the middle of the holes in the door.
- 4** Ensure the connector cable and leading tube have fed through to the inside of the door, gently pull if necessary. Checking it's not caught or trapped, as this could damage the cable.
- 5** Remove leading tube from the cable. Hold the external handle in place and fit the mounting plate (see next page).

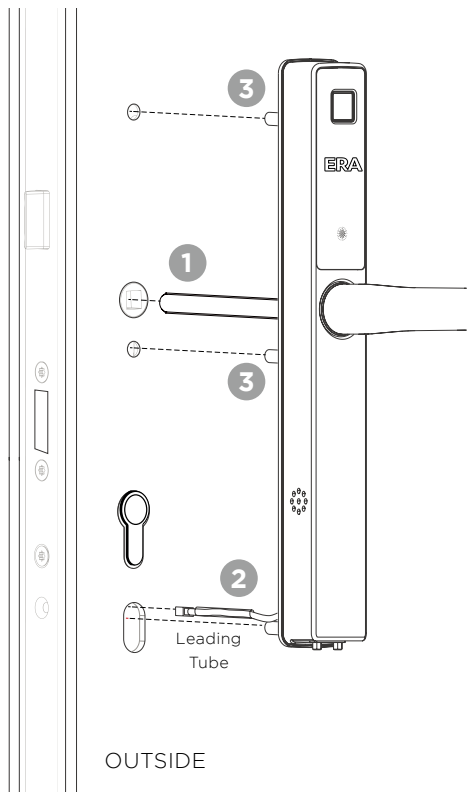

## Information

Please note you may need to increase the size of the bottom fixing hole to allow both the cable and screw to pass through.

# Installing the internal mounting plate

- 1 Ensure the mounting plate is in the correct orientation with the rubber pad against the internal door face.
- 2 Feed the electrical connector and cable through the bottom slot, you may need help to do this as you will be holding the external handle in position at the same time.
- 3 Push through and loosely tighten fixing screws (M, N or O) into the screw pillars, remember, there may only be 2 screws not 3, into the screw. Check the mounting plate is firmly against the door face.

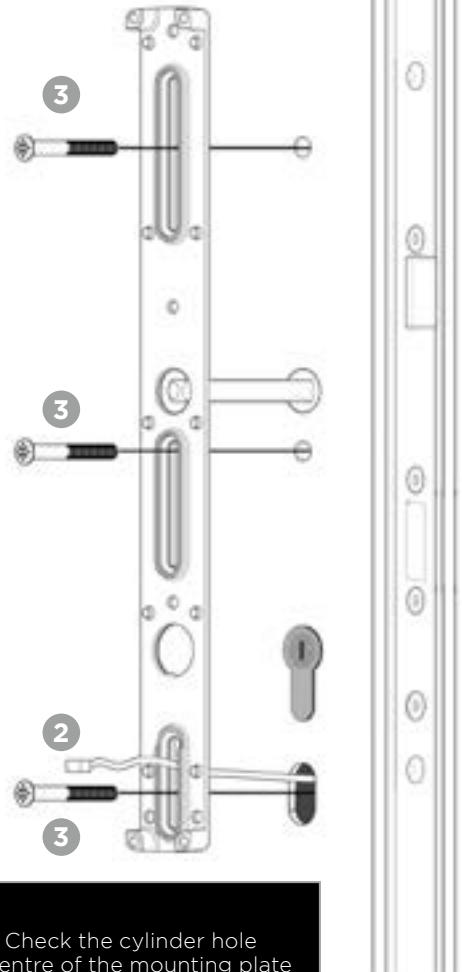
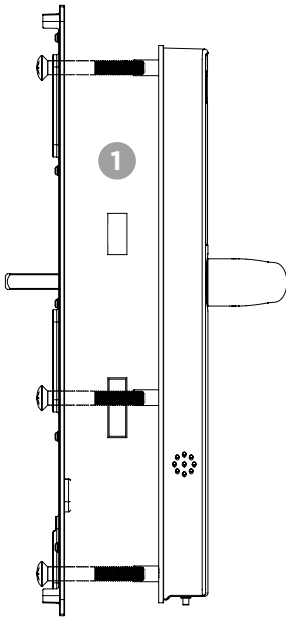
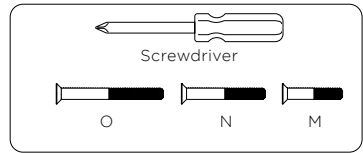

## Important

Do not fully tighten the fixing screws. Check the cylinder hole and spindle hole and lined up in the centre of the mounting plate holes.

# Fitting the drive bar

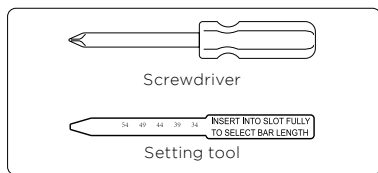

- 1 We need to determine the correct operating bar length to be used for your door. Using the setting tool supplied, push it fully into the slot in the operating cam.
- 2 The black mark nearest to the backplate shows the correct bar length. Withdraw the setting tool and before proceeding, please make sure the slot in the cam is in a vertical position. If not, please adjust before inserting the drive bar. There is a brass pin within the operating cam that can be pushed down (using the pointy end of the setting tool) and the cam rotated to ensure alignment.
- 3 Select the correct length of drive bar (see table below, as determined by the setting tool) from the box. Then, insert the wider square end in first, push firmly into the slot until it reaches the bottom of the operating cam.

Setting tool reading (mm)	Bar number	Bar length (mm)
34 - 39	F	35
39 - 47	G	42.5
47 - 51	H	50

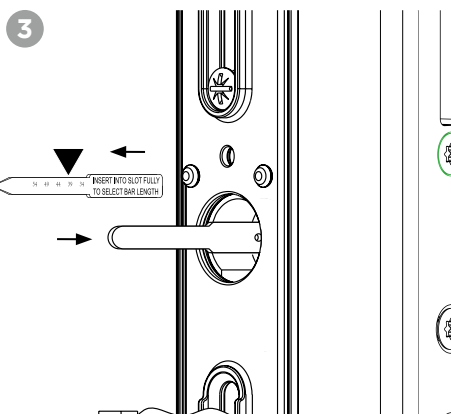
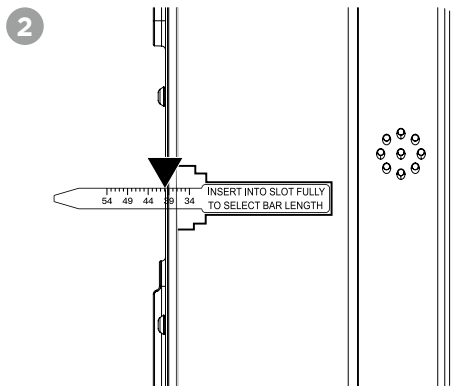
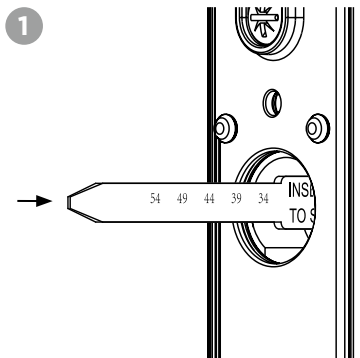

## Using the fitting jig to align

### Important

Please ensure the drive bar is vertical, please refer to previous page for details on how to adjust the operating cam to ensure the bar is vertical.

- 1 Slide the black plastic fitting jig over the spindle (as shown). Check the drive bar is correctly located in the slot.
- 2 Move the internal mounting plate slightly if required until the jig is fully located. The spindle and drive bar should align centrally with the holes in the mounting plate.
- 3 Once everything is correctly aligned, tighten fixing screws firmly but do not overtighten. Remove the fitting jig. Make sure the spindle and drive bar are still in the centre of their holes respectively.

### Important

Please ensure you use the fitting jig (provided). It **MUST** be used to ensure correct alignment before proceeding.

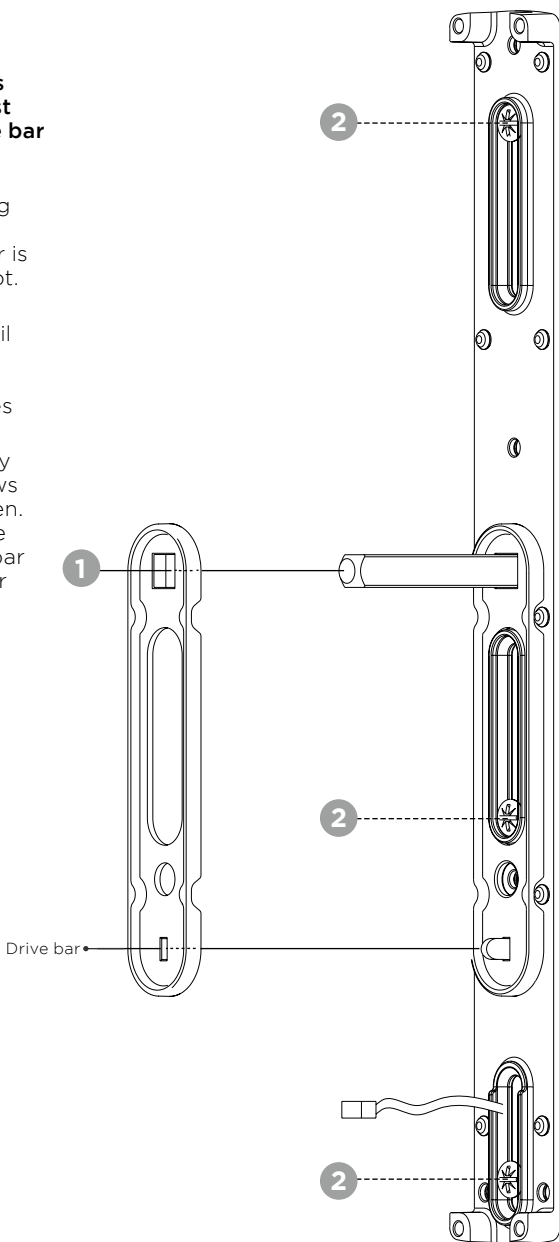

## Fixing the mounting plate

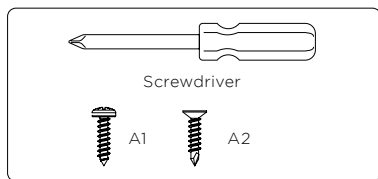

- 1 If the top of the mounting plate is not sitting flush with the face of the door, we recommend fitting the additional self-tapping screw A1 (supplied).
- 2 Some composite doors have steel skins, so it may be necessary to use a powered driver with a self-drilling screw A2 (supplied) instead.
- 3 Other optional (OP) fixing points are available if required (screws not provided).

### Information

**Screw A1** is a self-tapping screw.

**Screw A2** is a self-drilling screw and requires a pilot hole to be drilled first, prior to using.

Please be careful to tighten by hand to avoid stripping the door skin.

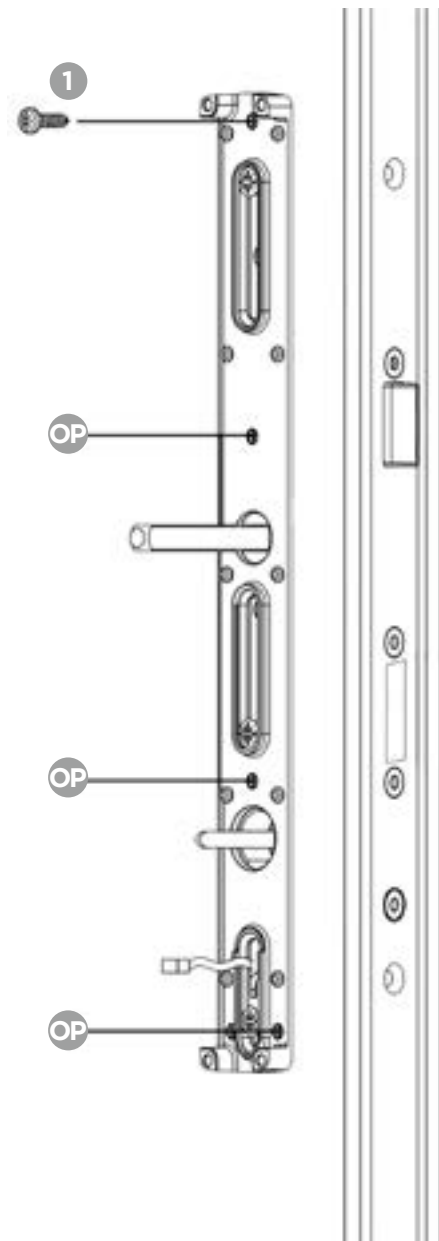



# Fitting the internal handle

- 1 Firstly, check that the handle lever is the correct orientation (see page 8). The battery cover and setting cover are removed to allow access to the screw holes.
- 2 Then, using the thumbturn, check that the alignment arrows on the cam on the back of the internal handle are vertical (as shown below).
- 3 Carefully connect the connector to the port in the internal handle (as shown). Ensure that the red side on the connector and red side on the handle port are aligned and push gently into the port. Ensuring that the connector is securely located into the back of the handle.

## Information

On the rear of the thumbturn, please ensure that the drive bar is vertical and the cam slot arrows are vertical before fitting.

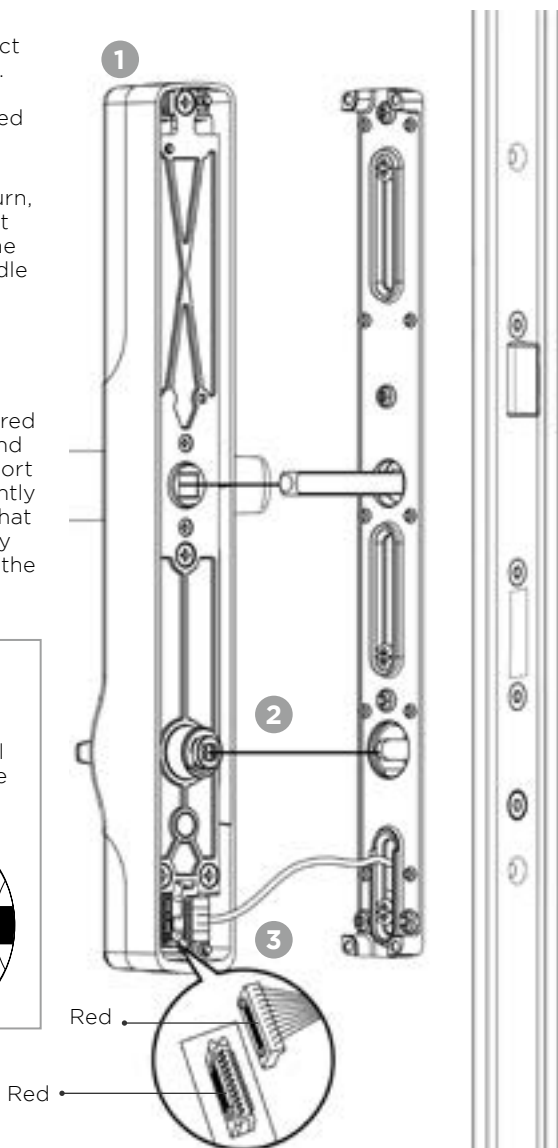
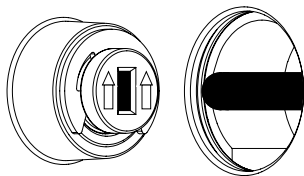

## Fitting the internal handle (continued)

### Important

**Please ensure the cable is tucked into the allocated slot around the thumbturn (as shown the diagram).**

- 1 Locate the handle onto the spindle.
- 2 Push the handle in slowly ensuring that the cable remains tucked around the thumbturn as shown in the diagram.
- 3 Check that the drive bar is fitting into the slot in the thumbturn cylinder and push the handle fully onto the mounting plate.
- 4 Finally, check that the handle is seated correctly on the backplate and that the cable is not visible (not caught under the edge of the handle).

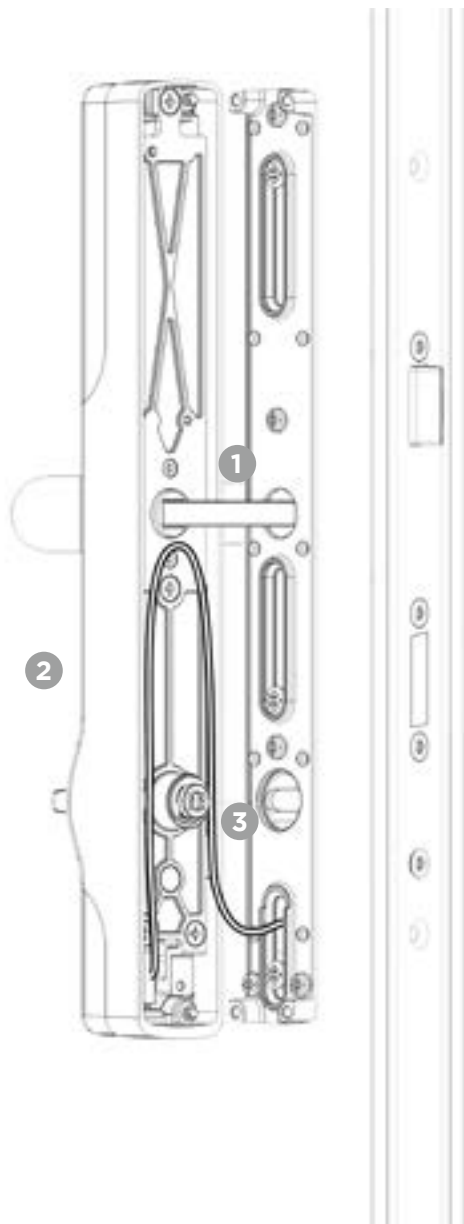

## Fitting the internal handle (continued)

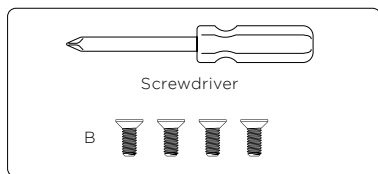

- 1 Fit the 4 fixing screws supplied, as shown. Please do this by hand (do not use a powered screwdriver). Do not overtighten the screws.

### Important

Please **do not** push down or lift the handle at this stage.



# Setting up the internal handle

## Important

Please do not turn the thumb turn until the sequence below has been completed.

- 1 Please insert the 4 AA batteries (not supplied) into the handle. Check orientation of the batteries before inserting.
- 2 When the batteries are inserted, you will hear a **'beep'** to confirm the batteries are correctly fitted and the handle is turned on.
- 3 The voice assistant will ask you to **'Please push the lever handle down'**, please do so and then **'Please lift the lever handle'**, again please do so. This is to confirm the direction of the handle lever.
- 4 You should then hear the motor turning. This process may take a few moments while the motor locates the pin and locks the door.
- 5 Try to push the lever down, if the handle has been correctly fitted, the door is now locked and the handles cannot be pushed down.
- 6 Fit the battery cover, with a slide and push motion. Secure with screw (C) provided using the Allen key.

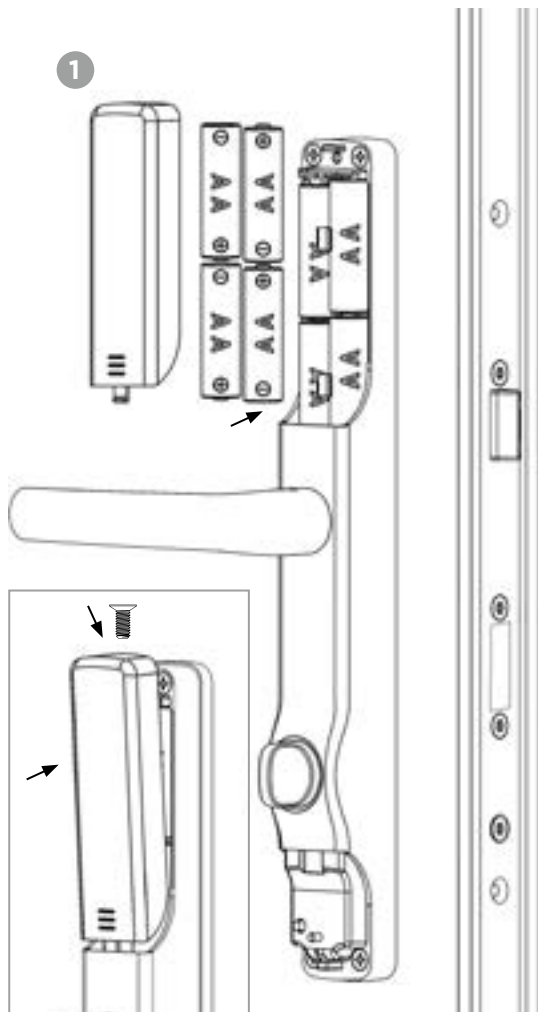

## Information

Estimated battery life is 6-8 months depending on usage and environment. It is recommended to change the batteries every 6 months for optimal performance. When batteries are running low, you will hear a 'low battery' warning upon each use of the handle. You will have approximately 50 warnings before the batteries deplete.

# Checking the thumbturn

To check the operation of the internal thumbturn.

- 1 Unlock the door from the inside by pressing the thumbturn in and turning the thumbturn. Turn clockwise if the handle is on the left side of the door. Turn anti-clockwise if the handle is on the right side of the door.
- 2 You will hear and feel a click, now you can push the handle down to unlock the door.
- 3 Once you are satisfied that the thumbturn is operating easily and isn't hard to turn or sticking, you can tighten the cam fixing screw (see page 7). Be careful not to overtighten and still leave a small amount of slack.
- 4 Once tightened, lift the handle to lock the door, then unlock via the thumbturn again. Make sure that the thumbturn is still operating easily and freely.
- 5 Please do not fit the setting cover yet.

## Information

If the thumbturn is sticking or is stiff to operate, the cam fixing screw may be too tight. Undo the screw by one turn and try again.

If it is still sticking, please contact the technical support helpline.

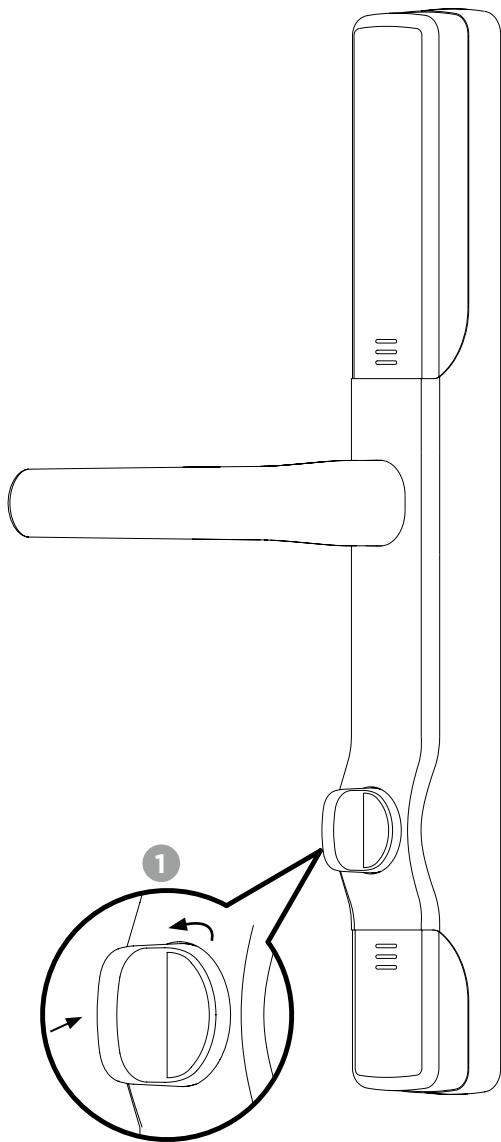

## Fitting the setting cover

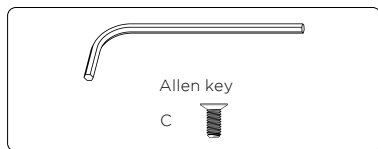

We recommend you use the App to set up the handle, please refer to the User Manual to do this.

However, you can also set up and use the handle manually (without the App). Please refer to the User Manual for details.

- 1 Once set up is complete, you can fit the setting cover to the bottom of the handle and secure with the screw provided (C). This is a security screw for child safety, please use the Allen key supplied.

### Information

Please retain the Allen key if the cover needs to be removed in the future.

### Important

It is imperative that you **fully test** the door before leaving the property after installation.

Please check that you can lock and unlock the door successfully.

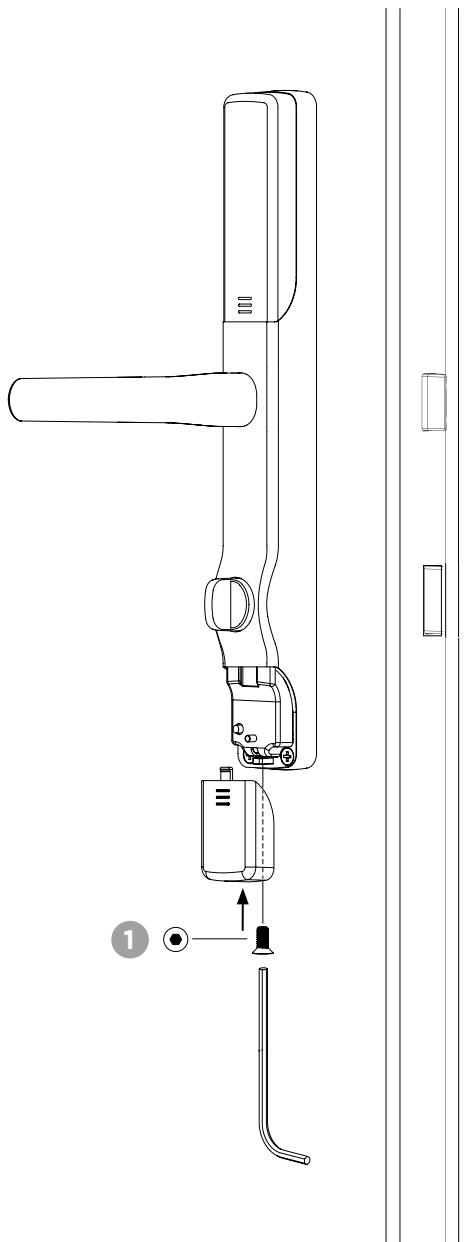

# Creating an account and adding your Smart Universal Door Handle

1



Download the **ERA Smart Home app** (iOS and Android). Turn on your Bluetooth.

**Please ensure you download ERA Smart Home app not the ERA Protect app.**

2

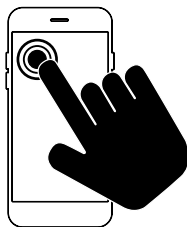

Open the app and create an account by completing the required details. Please review and agree to the terms of service.

3

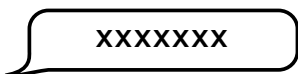

A verification code will be sent to your registered email account. Enter the code when prompted.

4



On the next screen select "ERA Protect EP1".

5

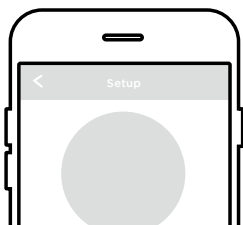

Stand within 2m of your handle and ensure the batteries have been inserted. Press "Continue".

6

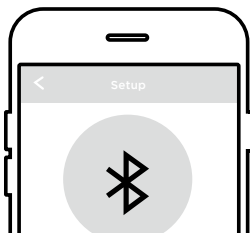

Turn on Bluetooth or if Bluetooth is already enabled please press "Continue".

# Creating an account and adding your Smart Universal Door Handle (continued)

1



Select your ERA Protect EPI device.

2

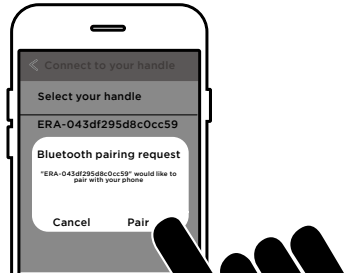

You will receive a "Bluetooth Pairing Request". Click "Pair" to initiate.

3

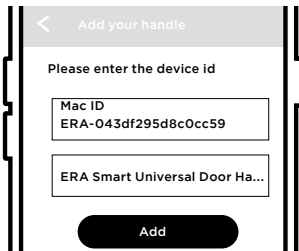

Once connected, enter a name for your handle (for example 'front door') and press "Add". This will now become the name of your handle for your account.

4

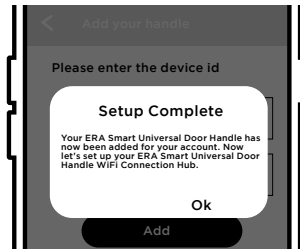

You will see a notification that your account has been created and the ERA Protect EPI device has been successfully added.

At this point you can also set up and add the ERA WiFi Connection Hub see page 26.



# Adding your Smart Universal Door Handle to an existing ERA Smart Home account

1

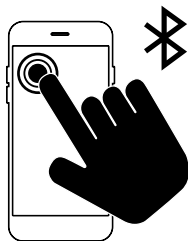

Turn on Bluetooth in your phone settings.

2



Open the ERA Smart Home App (iOS or Android).

3



Select ERA Protect EP1 from the menu and press "Add".

4

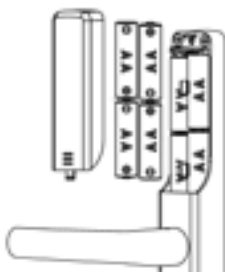

Insert your batteries into your Smart Universal Door Handle.

5

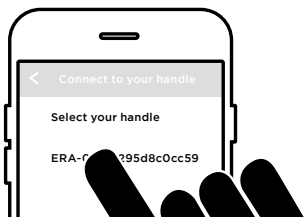

Select your ERA Protect EP1 device.

6

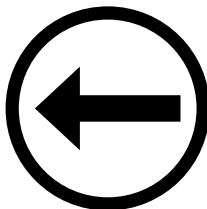

Follow steps 7 to 9 from the previous page.

# Adding an ERA WiFi Connection Hub from the settings

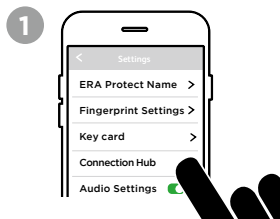

Open settings in the ERA Smart Home app and press "Connection Hub" This will allow you to connect an ERA Connection Hub device to your handle.



Press "Set up Now" and follow the on screen instructions.

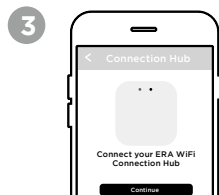

Please ensure your Connection Hub is plugged into a power source and wait for a flashing blue light and then a flashing red light. Press "Continue", the Hub will now start scanning for your EPI handle.

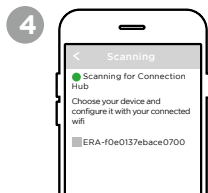

When you see your handle name, select and then select your WiFi network from the list. You will need to enter your WiFi network password, then press "Ok".

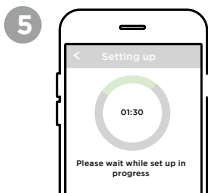

A timer will display once you have connected to your WiFi. This will indicate how long is needed to connect the Hub to your handle. Keep the app open and do not close the screen. If you do, repeat the instructions from step 1.

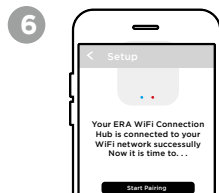

Once set up is complete, read the notification onscreen and select "Start Pairing".

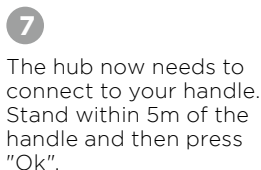

The hub now needs to connect to your handle. Stand within 5m of the handle and then press "Ok".

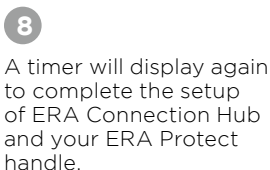

A timer will display again to complete the setup of ERA Connection Hub and your ERA Protect handle.

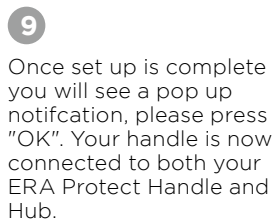

Once set up is complete you will see a pop up notification, please press "OK". Your handle is now connected to both your ERA Protect Handle and Hub.

# Warranty information

## Our Promise

We at ERA firmly believe in the quality of our goods. Our technology achieves outstanding performance and durability and we can therefore offer, in addition to your statutory rights, an additional limited guarantee.

**Smart Security:** a 2 year guarantee commencing on completion of installation.

**Critical Security and Firmware Updates:** for 4 years from the major version date of the software within the ERA Protect.

If a material defect occurs in the hardware or smart security before the end of the relevant guarantee period set out above, ERA will (in its sole discretion) replace the hardware or security (or the defective part thereof) free of charge.

ERA may, as part of any replacement of hardware or smart security, supply alternative hardware or smart security that it considers to be of similar or better quality where the particular hardware or smart security subject to the defect are obsolete or otherwise unavailable.

The ERA Protect Guarantee is only valid when the following terms and conditions are met in full:

- This limited guarantee is not transferable and is extended only to, and is solely to the benefit of, the original purchaser of the product. Please retain your dated sales invoice as proof of purchase and forward this to us if you wish to make a claim under this guarantee.
- Products must be installed, used and maintained in accordance with our instructions otherwise the guarantee will be invalidated.
- The product must not be damaged or modified in any way nor must it have been subjected to any unauthorised repairs.

## Exclusions

To read the guarantee terms and conditions, including exclusions in full, please visit [eraprotect.com](http://eraprotect.com). The ERA Protect Guarantee is in addition to your legal rights. It does not exclude, restrict or modify your legal rights, including under consumer law in the UK.

## To make a claim

You can contact us on 0345 646 1487 (during office hours) and we will then provide you with assistance in making your claim\* under the ERA Protect Guarantee.

\*Terms and conditions apply.

## Recycling and disposal

Disposal of this product is covered by the Waste Electrical or Electronic Equipment (WEEE) Directive. It should not be disposed of with other household or commercial waste. At the end of the product's useful life, the packaging and product should be disposed of via a suitable recycling centre.

## EC Declaration of Conformity

ERA hereby declare that this equipment complies with the essential requirements of the Radio and Telecommunications Terminal Equipment Directive 2014/53/EU. A copy of the EU Declaration of Conformity is available at [eraprotect.com](http://eraprotect.com).

## Data Protection

ERA is committed to processing your personal data in compliance with all applicable data protection laws. For more information regarding how we process your personal data, please see our privacy policy at [eraprotect.com](http://eraprotect.com) or it is available from us on request

All rights reserved. Phone not included.



## IMPORTANT

### Things to remember

- 1 Please ensure that you read the manual fully before attempting installation of the handle.
- 2 **Please ensure you hold the door open in the unlocked position while installing the handle to prevent getting locked in or out of the property. It is also imperative that the handle is installed with the multi-point door lock in the unlocked condition, otherwise the handle will not sequence correctly during installation.**
- 3 Please ensure you correctly install, set up and test the handle before leaving the property.
- 4 If you experience any problems with your installation, or if you need any help setting up or operating the ERA Protect handle, please contact our customer helpline.
- 5 In the unlikely event you should be locked out of your property, we would advise speaking to a local locksmith.

Please scan the QR code to access online User Manual (including handle set up) and latest FAQs, videos and downloads:



**ERA Home Security Ltd**

Valiant Way, Wolverhampton,  
West Midlands, WV9 5GB

Customer Helpline: **0345 646 1487**  
**eraprotect.com**