

Classic Cam Lock and Keeps

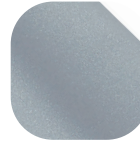

Features

- Classic design**
 Sits discreetly on the window with key deadlocking
- Perfectly Matching**
 Suited Classic Bottom Sash Knob for a perfectly matching window
- Colour coordinated screws**
 Perfectly match to the Cam Lock, even down to the small details
- Designed for PVCu, Timber and Aluminium sliding windows**
 To suit all window materials, we have a range of different keeps to suit specific profiles
- Available in the complete range of Hardex finishes**
 Perfectly matching to the full Fab&Fix range of products



Premium Satin



Hardex Chrome

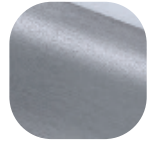

Hardex Graphite



Hardex Bronze

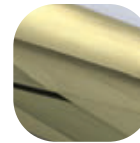

Hardex Gold

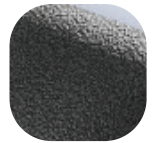

Antique Black



Hardex Pewter



White



Black

Classic Cam Lock and Keeps

Ordering Details

Product

Classic Cam Lock

Finish	Part No.
Hardex Chrome	VHCLHC01
Hardex Bronze	VHCLHB01
Hardex Gold	VHCLHG01
Hardex Graphite	VHCLGR01
Hardex Pewter	See table below – packaged as a set Lock and Keep
Antique Black	See table below – packaged as a set Lock and Keep
White	VHCLWH01
Black	VHCLBK01
Premium Satin	VHCLPS01

*For windows over 800mm wide, 2 cam locks and keeps are required.

Classic Cam Lock Keeps

Finish	8mm Keep	11mm Keep
Hardex Chrome	VHKPHC08	VHKPHC11
Hardex Bronze	VHKPHB08	VHKPHB11
Hardex Gold	VHKPHG08	VHKPHG11
Hardex Graphite	VHKPGR08	VHKPGR11
Hardex Pewter	See table below – packaged as a set Lock and Keep	
Antique Black	See table below – packaged as a set Lock and Keep	
White	VHKPWH08	VHKPWH11
Black	VHKPBK08	VHKPBK11
Premium Satin	VHKPPS08	VHKPPS11

Lock and Keep Set

Finish	8mm Keep	11mm Keep
Antique Black	VHCLAB0108	VHCLAB0111
Hardex Pewter	VHCLPT0108	VHCLPT0111

Accessories

Description	Part No.
Spare Key	723-KEY

Technical Information

Corrosion Resistance

Meets the requirements of BS EN 1670:2007 Grade 5 (480 hours)

Material Specification

Cam Lock and Keep:	Zinc Die Cast
Keys:	Steel
Coatings:	Hardex Chrome, Hardex Bronze, Hardex Gold, Hardex Pewter, Antique Black, Hardex Graphite, Premium Satin, White and Black.

Packaging

Cam Lock: Individually bagged, 50 per box
Keep: Individually bagged, 100 per box
Cam Lock and Keep: Packaged together, 50 per box

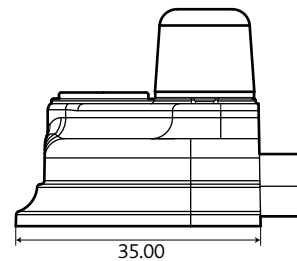
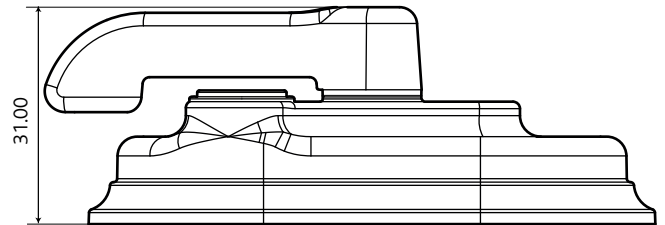
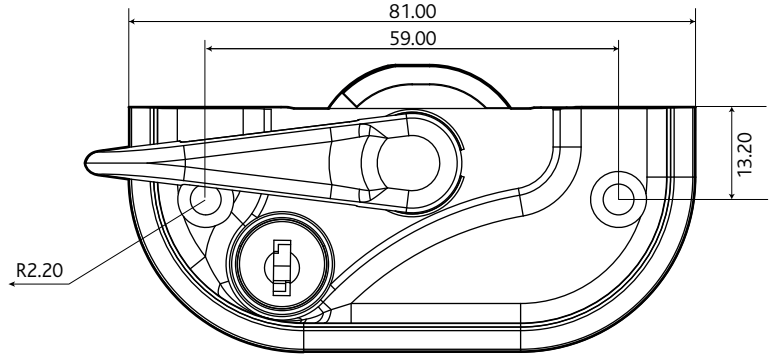

Diagram not to scale.

All dimensions are in mm and are nominal.

Fab&Fix reserves the right to change specification without notice. It is the responsibility of the window manufacturer to ensure that the finished product meets any required safety and performance specification.

Maintenance

For continued protection of the quality finish and appearance, we advise routine cleaning of all our external hardware. We recommend wiping it with a clean cloth soaked in warm water and mild detergent every month. Please refrain from using heavy-duty cleaners, containing Chlorine or Potassium. Moving parts should also be lightly lubricated using a light non-acidic mineral oil (e.g., "3 in 1") at least twice per year. The product may need to be adjusted and fixings tightened to ensure a satisfactory operation. This procedure is particularly essential if products are used within a 25-mile radius of coastal areas or close proximity to building sites or large industrial areas, where more frequent cleaning may be required to prevent the accumulation of corrosive contaminants.